

UNFOLD

Narratives of Bohuslän manifested in a public sauna



CHALMERS
UNIVERSITY OF TECHNOLOGY

Master's thesis Spring 2021

UNFOLD

Narratives of Bohuslän manifested in a public sauna

Maria Ekström & Siri Bjärhall
Chalmers School of Architecture
Department of Architecture & Civil Engineering

Examinor: Marco Adelfio
Supervisor: Nils Björling

Architecture and planning beyond sustainability
Rurban transformations

Abstract

In the westernmost part of Sweden, villages lie like a string of beads along the coast; Grebbestad being one of these coastal villages. The community derives from a tradition of fishery and is today characterized as a summer paradise for tourists and part-time residents. The increasing number of visitors and part-time residents is a resource that spares the community from common small-town problems. Tourism composes a significant source of income and primary incentive for the community's development. Simultaneously, the absence of tourists in wintertime leaves a negative imprint when most stores and restaurants close down, resulting in empty and abandoned central spaces. Another aspect relates to the expectations and ideas of Grebbestad that makes it attractive. As an old seaside resort the place is formed by visitors' expectations over a long time, leading to a preservation of, for visitors, attractive characteristics of the community. This, so-called, tourist gaze has come to create the dominating narrative today as it also defines the place's future narrative.

In this master thesis, the dominating narrative of Grebbestad is investigated and challenged. As architects, being in possession of telling the story of a place, we, for this degree project, explore the narrative as an architectural tool and set in relation to site representation, i.e. the process of how a site can be constructed. The thesis is conducted through theoretical investigations and design elaborations that together examine and materialize alternative narratives. The narrations constitute the basis for a design proposal in form of a sauna, a building that can be utilized throughout the year by a public and multifaceted group of users and hold features that can create a sense of belonging, responsibility and maybe even some kind of pride. The thesis takes a critical stance on which stories are visible and reflects upon what processes shaping them and, as well, on how architecture becomes a valuable tool for formulating and enhancing the different narratives of a place.

Key words: *Place identity, Public space, Tourism, Coastal communities, Sauna*

Authors

Siri Bjärhall

**Chalmers University of Technology,
Gothenburg**

Sep 2019 - Jun 2021

MSc in Architecture; *Matter, Space Structure;
Architectural Heritage and transformation;
Planning and design for a sustainable
development in a local context*

Arkitekterna Krook & Tjäder, Gothenburg

Sep 2018 - Feb 2019

Internship

Grebbestads Folkhögskola, Grebbestad

Sep 2017 - Jun 2018

Ceramics

**Chalmers University of Technology,
Gothenburg**

Sep 2014 - Jun 2017

BSc in Architecture

Maria Ekström

**Chalmers University of Technology,
Gothenburg**

Sep 2019 - Jun 2021

MSc in Architecture; *Architectural Heritage
and Transformation; Planning and design for a
sustainable development in a local context*

Uppsala university, Visby Gotland

Autumn 2020

*Cultural heritage and use of history: concepts,
perspectives and ethnography.*

Grebbestads Folkhögskola, Grebbestad

Sep 2017 - Jun 2019

Wood / furniture carpentry

**Chalmers University of Technology,
Gothenburg**

Sep 2014 - Jun 2017

BSc in Architecture

Preface

The subject of this master thesis originates from our own years of living in Grebbestad. The experience of the harsh and dark winters created a longing for a space like the sauna. Together with a local boat club, we built a sauna in an empty boathouse, which started new experiences of both the local community and architecture. There are several aspects of the sauna, making it interesting for an explorative architectural project. It is a freestanding building in a scale suitable for experiments and explorations of architecture and landscapes. Parallel, we have come across shared saunas in other coastal villages, giving us the idea to unravel the sauna's potential to strengthen local communities in Bohuslän.



Reading instructions

Introduction gives a broader understanding to the investigated topic to subsequently end up in the thesis aim.

Method outlines the architectural approach to the topic and describes how the project has proceeded.

Site introduces the geographical context of the thesis presented in two scales. Grebbestad makes up the wider context, and Vadskär, an islet located in Grebbestad, is the site on which the design intervention takes place. A main focus is put on public places with its seasonal changes and transforming building stock related to development of the town.

Discourse covers the theoretical investigation of the work that provides a broader understanding of; the notion of place identity in relation to the topic; how architecture relates to place and uses narrative as a tool; public space in a rural context leading into the sauna as an example. The chapter concludes with an interpretation of site inventories, literature studies and sketching exercises merged into four hypothetical narratives.

Design proposal manifests a building proposal of a sauna presented in architectural drawings and perspective renderings continuing the discussion of how to materialize the process.

Discussion wraps up the thesis work with an exposition in; place, narrative and architecture/tourism; the fragility of small communities; synergic effects; and a need for new rural domains. Discussion ends with a personal reflection upon the work. synergic effects; and a need for new rural domains. Discussion ends with a personal reflection upon the work.

Content

Introduction	10
Method	16
Site	22
Discourse	36
Design proposal	56
Discussion	78
References	82

INTRODUCTION

Background & problem setting

A large influx of herring during the 1500s constitutes a significant reason for the development of the coastal villages of Bohuslän that spring from a tradition of making a living from what the sea has to offer. Since then, shoals of herring have in periods approached coastal areas of Bohuslän and played a significant role in the village's growth and survival. Since the turn of the 1800s, Bohuslän started to attract tourists. Wealthy visitors from the cities came for recreational purposes as bathing in salt water was considered as healthy, initiating the development of the coastal villages into bathing resorts. The small town Grebbestad became a resort already in 1844 as the mud in the bay was held as health-promoting and bathing facilities for hot and cold baths were built. The summer guests stayed in bathing hotels or with locals that rented parts of their homes for summer guests. As the 1900s progressed, it became increasingly difficult to make a living from fishing and the population decreased in the coastal villages. Simultaneously, the interest in buying and building holiday homes increased (Bohusläns museum, n.d.).

During the summer months, part-time residents almost double the population in many municipalities today and are considered

an essential asset for Bohuslän (Tillväxt Bohuslän, 2014). Additionally, the coastal villages are filled with summer tourists whose presence further constitutes a basis for commercial service and job opportunities for permanent residents (Larsson & Robertsson, 2012). When autumn comes, the tourists get fewer, and most part-time residents lock up their houses and leave. Without them, restaurants and much of the commercial service closes. Both public places and private dwellings owned by part-time residents stand empty and dark until next summer.

The presence of tourists entails a dilemma with partly conflicting interests with both positive and negative consequences at the same time. On the one hand, tourism spares the coastal communities from problems that other small towns suffer from. In planning, tourists and part-time residents are considered not just a significant asset but a primary driving force for the development of the municipalities (Tanums kommun, 2006; Tillväxt Bohuslän, 2014). On the other hand, tourism has both social and spatial consequences. Over the years, the inhabited areas along the west coast have transformed from production landscapes into consumption landscapes that mainly

address tourists and part-time residents. The time of the year when the tourists are absent, this leaves a negative imprint with empty and abandoned spaces.

The environment that a tourist visits is subject to what Urry and Larsen (2011) describes as the *tourist gaze*, a socially constructed understanding of the world viewed by the tourist. This view on a place can affect the various expectations and the ideas of what a place is and what needs to be preserved in order for a region to retain attractiveness, as for Bohuslän. The tourists' expectations do not always comply with the residents' view on the same place. An example of this kind of contradicting opinions surfaced when Orust municipality produced a new detailed plan for the harbor area in Mollösund. The planning manager Rickard Karlsson explained how the house owners perceived the proposal differently: "Most permanent residents applauded, while the part-time residents, who are here a few weeks a year, were least likely to see a development of the place. They want it a bit like a museum and sit on their porch with a drink and their friends visiting." (Innocenti, 2019).

The current and contradictory situation, which we call the tourist paradox, is thus how seemingly important the inbound tourism has become for the economy and survival of the coastal societies, and their dependence of attracting visitors, at the same time as it occurs under special terms and conditions in that the tourism also limits and strongly influences how the societies may develop, expand and look like due to the visitor's expectations.

The biggest inflow of people is concentrated to an intense and short period during the summer to almost totally fade out during the rest of the year, leaving an empty and desolate society. This is when everyday life starts and takes place for the permanent residents.

How is it then possible to accommodate for temporary visitors' and different groups of residents' various expectations and demands on a place when developing a society? How can architecture serve as a tool and a means for bridging the interests of different target groups? How can the architectural narrative be used for imagining and exploring different future prospects?



Purpose and aim

This thesis uses narrative as an architectural tool to explore and challenge dominating and unambiguous stories about a place, being one of the factors with a prominent impact on a local community's development. In the context of Grebbestad, tourism represents an example of how a dominating narrative is produced which forms a point of departure for the thesis work.

The aim is to critically question which stories are visible and further reflect upon what processes that are shaping them. By asking ourselves the question of how architecture can be a valuable tool for formulating and enhancing a place's different narratives, our intention is to unravel potentials valuable in a further development of the local community.

Delimitations

While looking at tourism as an asset, we still find reasons for problematizing its influence on the place. In that sense we do not strive to work against tourism in the coastal villages of Bohuslän, or in any way choose a side between different groups of residents and visitors. We approach the increasing tourism in Grebbestad as an ongoing process and that needs to be addressed.

METHOD

Method

Overarching approach

The overarching method used in this thesis is Research by Design; “constituted by the design process itself, including materials research, development work, and the critical act of recording and communicating the steps, experiments, and iterations of design” (Hannington & Martin, 2012, p. 146). The method is further distinguished by an interaction between theory and practice, and when applied in the context of this thesis, a selection of theories emerges in parallel with sketching elaborations and site inventory. The interplay has contributed to a process of alternately broadening up and narrowing down as we have dug into big open questions and unconditional sketching to eventually concretize and specify our work before entering a new iteration or perspective. In this way, we have both reached a level of discussion of the problem setting as the creative and intuitive process of sketching has flowed freely. Gradually we have built up an understanding of how to materialize our thoughts and what the theories mean for the site.

Our interest in the relationship between theory and practice departs from how architects confront different scales. Investigations in comprehensive planning processes dealing with complex questions, are often combined with a process where form and function play a more significant role. A broader perspective of theoretical thinking and connectivity is combined with an exact and concrete notion of matter striving for a manner of think big, act small.

Narrative thinking

As a way to practice Research by Design, *narrative* is a central concept in this thesis, used as an architectural method or tool but also to mention and describe ideas, interpretations or stories about what a place is. The links between narratives and place is explored further in the discourse chapter. For now we will just focus on the connection between the act of narrating and design work. The concept narrative can be defined differently and is used for example in literature to describe “texts that present events in a real or fictional process in chronological order” (narrativ, 2021). Gerards and De Bleeckere (2014) tests in *Narrative Thinking in Architectural Education*, a method for architects to separate themselves from being the ones telling the story. They depart from Ricoeur’s thoughts of narrative as a vital phenomenon for human existence, not just occurring out there but being completed in the act of listening or reading. Narratives build our identities as well as uniting us. Gerards and Bleeckere (2014) mean that narrative thinking and designing is a collaborative process that designers use as they thoughtfully let abstract or concrete tools and materials come together and reshape into something new. Imagination is thus a key aspect to empathize and engage in others and to look beyond what is in our immediate vicinity.

Site inventory

Based on old and new observations, understanding how public spaces are used now and in the past, the inventory includes understanding of the development of the settlement in Grebbestad in a historical perspective. Since we are already familiar with both the broader and the limited geographical context, we start from our preconceived notions and try to deepen and at the same time question them.

Literature studies

The project involves literature studies and architectural references. A fundamental concept is place identity, which we study based on two opposing theories. By studying several theories, rather than one main, we are able to put together our own theoretical framework to help us answer our questions.

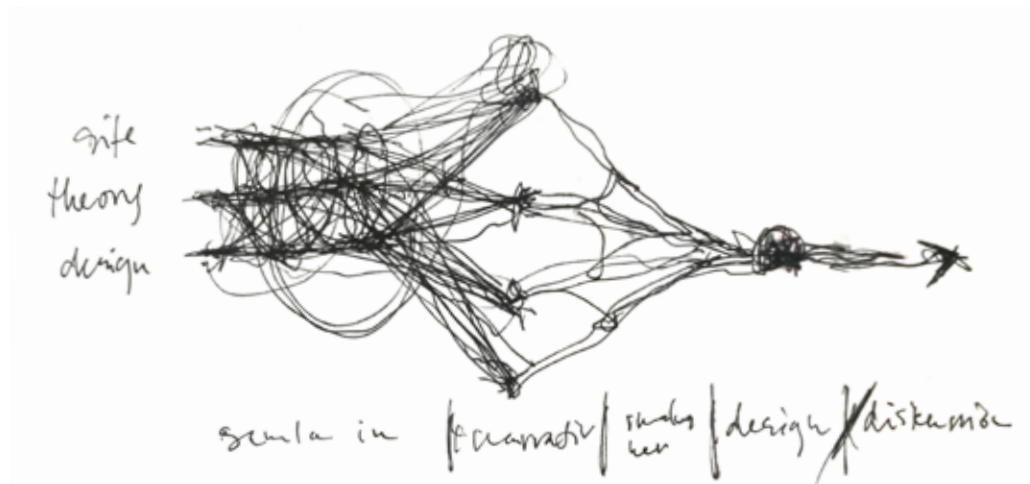
Elaborations

In a series of sketches, both place and sauna are explored from the notion of materials, movements, outlooks, and distance. To answer questions such as who the place belongs to and how it is experienced. The elaborations are a way of materializing the problem setting and translating it into form as well as the sketching process accentuate new thoughts and perspectives of understanding.

As our theoretical understanding of the power of narrative develops, we explore the narrative's influence on Grebbestad and Vadskär. This is done by shaping narratives about Grebbestad based on theory, inventory, and our own experiences. The narratives are based on what we see as existing stories about the place. At this point, the sauna becomes a constant parameter for bringing our narratives together with architecture.

Design proposal

The design proposal is an additional way to problematize the dominant narrative in Bohuslän by looking at the architect's actual influence over the site. In this way we would like to underline that the design proposal is to be seen as much as part of the investigation as a result of it.

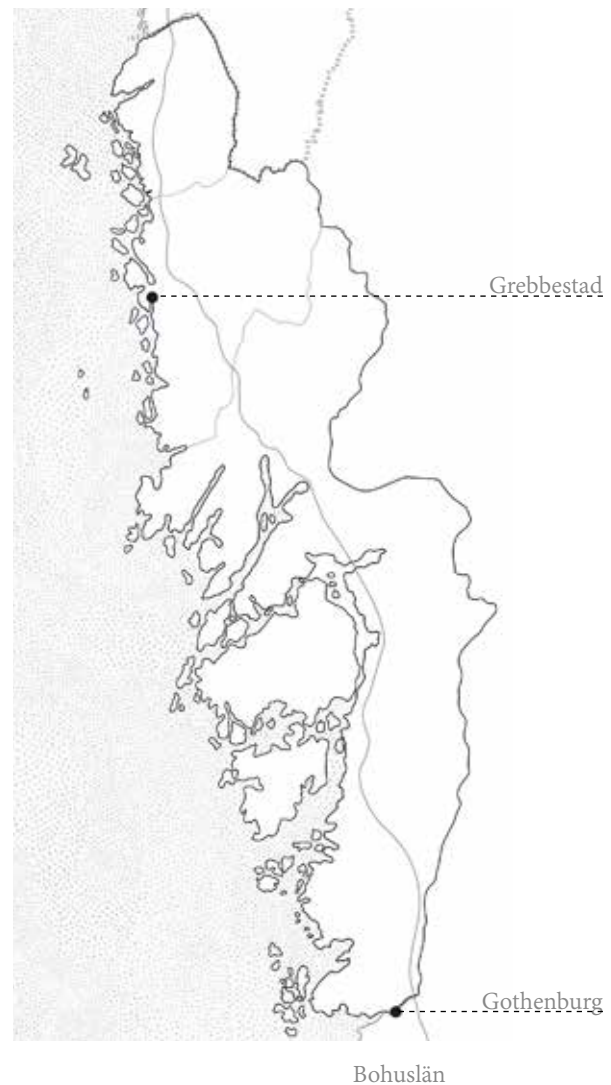


explore | narratives | concretize | design | connect & discuss

SITE



scale 1:8 000



Grebbestad

In the northern Bohuslän, Grebbestad is located about 8 km from the highway that extends from Gothenburg to Oslo. Public functions and services are shared between Tanumshede and Grebbestad, both located in Tanum municipality. Tanumshede holds the essential community services, as health care center, school, library, and municipality building, while Grebbestad, to a larger extent, is focused on tourism and fishery. In a town with an apparent relocation of inhabitants and a population older than the national average, Grebbestad Folkhögskola contributes both to young people as more service to stay open all year.



1. Central parkinglot



2. The Church



3. The Square



4. Commercial service



5. Backside



6. Everyday



7. Pier promenade
and Stöberget in the
background



8. Vadskär



9. The beach area

Public space

The contrasting seasons in Grebbestad are visible in the built environment. Most of the year-round services are located around a huge parking lot [1], dimensioned for peak season and therefore mostly an empty space the rest of the year. Still this is a place where you bump into someone you know, sit on a bench or just wait for the bus. The church [2] is located in the northern part of Grebbestad, and has, as in many other places, acquired an increasingly less important function as a public space. At the square [3], café Sjögrens i Backen is located, open all year round, there is also a boule court and playground. Most of the service around the square stands dark and silent except from high season. Closed and abandoned commercial functions as restaurants and shops leave a large imprint in Grebbestad character during winter [4]. Tourism also contributes to a "backside" of Grebbestad for goods and waste [5]. At the same time, an ongoing everyday life is visible in a practical and less picturesque side of the community [6].

Along the eastern side of the bay stretches a pier promenade [7], connecting the center of town with the beach in the south. The path is a popular route for tourists, but also important communication for bikes and pedestrians year round. Adjacent to the promenade, narrow stairs lead up to the steep rock wall of Stöberget which separates the northern and southern part of town. From here you get a full view of the horizon and an unusual opportunity to overview the whole town. Continuing on the promenade, the small islet Vadskär [8] constitutes the end of the harbour. The beach area [9] has gone through a facelift in recent years with a new walkway, seating and playground. Except for the high season, the beach stands fairly empty while the football field on the other side of Grebbestad rather lives up during autumn and spring.



10. Traditional building typology



11. Mid century housing



12. Contemporary housing



13. Traditional boat house



14. The harbour, 1896 (Fig. 1)



15. The harbour today



16. Previous bath house (Fig. 2)



17. TanumStrand



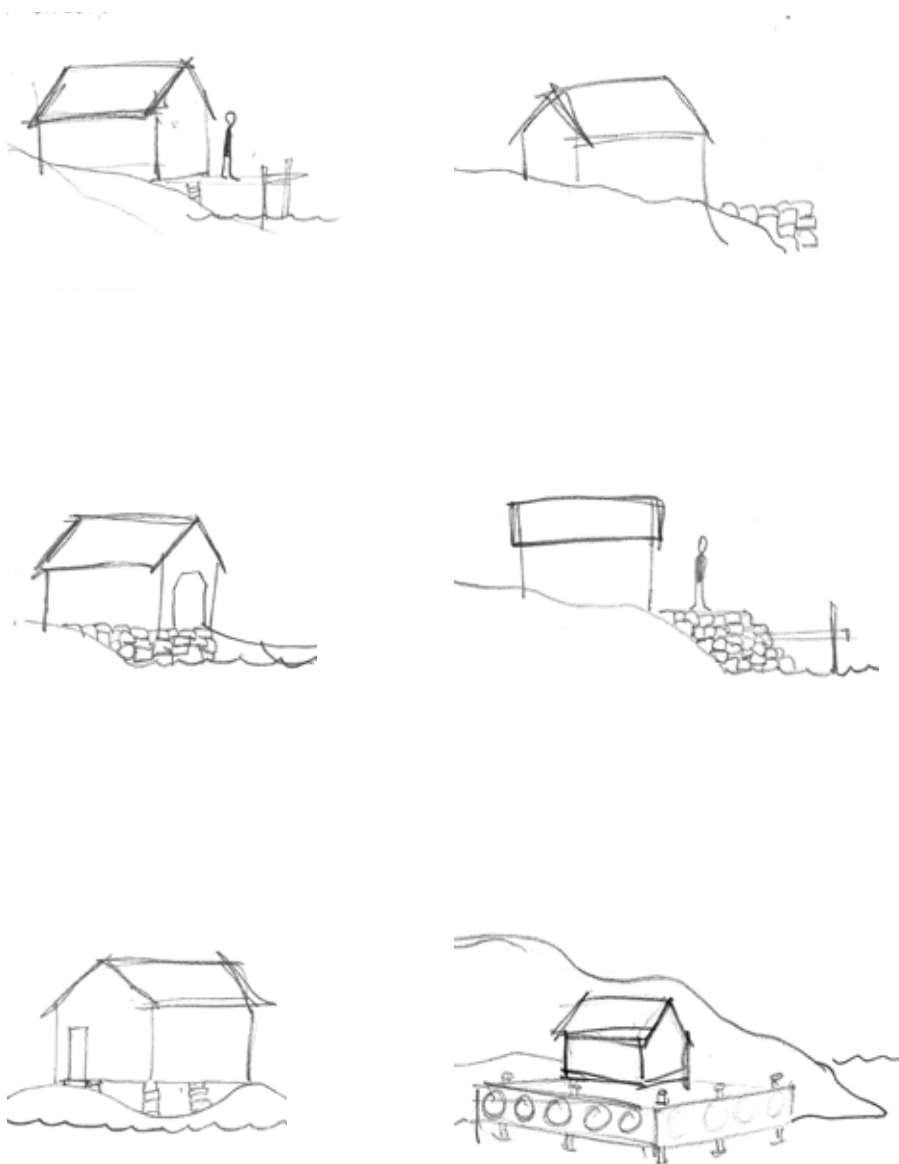
18. Sportshopen

Historical layers

In addition to the seasonal changes in Grebbestad it is possible to trace how the built environment has developed over a longer time. The city center is characterized by typical Bohuslän building tradition [10]; small single-family houses closely located and adapted to the terrain and climate. The once simple homes, sometimes originating as far back as the 1700s, have over the years become sought-after holiday homes. A city plan for Grebbestad was made in the 1930s (Tanums kommun, 2010) and the buildings are then arranged in a clearer structure. It is possible to find growth rings from the entire 20th century, built according to prevailing ideals [11] without connection to the traditional Bohuslän typology. Amongst the more recently built houses, a tendency is that they are located with an increased focus on view rather than protection [12]. Often inspired by the bohus typology, with gable roofs and the gable side oriented towards water, a modern interpretation of the boat house [13].

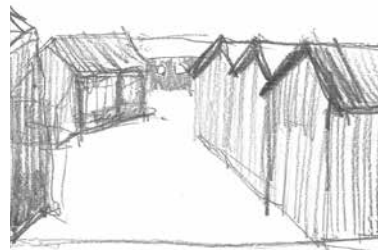
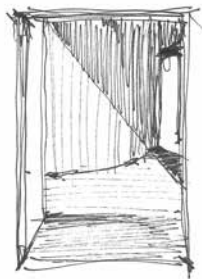
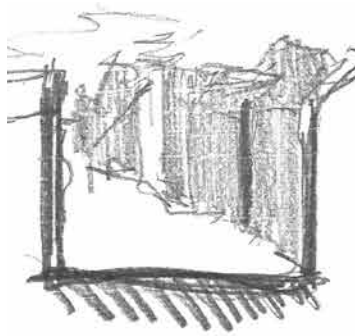
The harbour is protected between the hills and is a decisive reason for the existence and location of Grebbestad. By the old steamboat pier [14], the fishing harbour is still in activity, but the rest of the harbour is mostly for private and guesting boats [15]. At least two different bathhouses have previously existed in Grebbestad [16]. The latest was located by the beach but was demolished in the 70's. In 2008, the municipality initiated a proposal for a new bathhouse on Vadskär, but it has never been realized.

The increasing number of visitors in this area have resulted in large scale commercial functions, located into outskirts of Grebbestad. TanumStrand [17] was built in the 90s. In addition to tourist facilities and a conference center, hundreds of summerhouses are located in the area. Another example is Sportshopen [18], which not only offers cheap outdoor equipment but also an activity park, restaurants and yearly events.



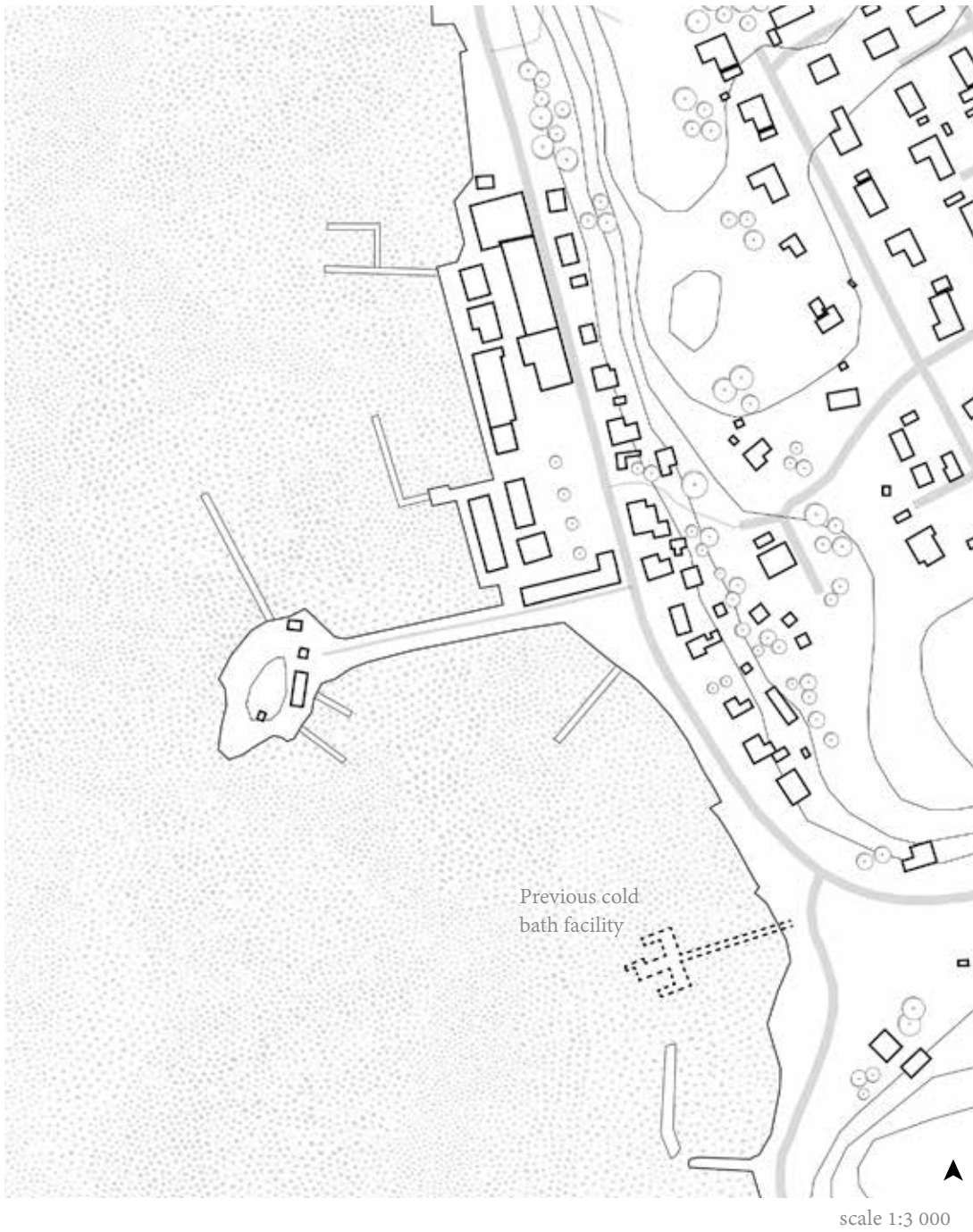
Boathouse

The common typology of the boathouse are situated differently in the landscape, demonstrated in the sketches. It stands between land and water, often elevated from the ground due to an uneven terrain. Some balance on narrow pillars of stacked stones while others resemble the more classic masonry stone foundation, common in Bohuslän. They are entered either from land or water, making the two gables main sides.

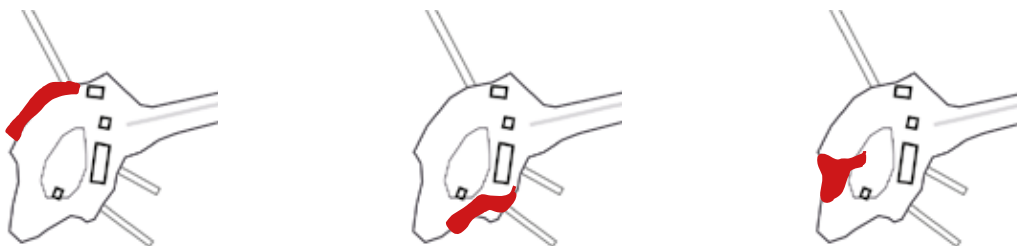


Sequences

A walk through Grebbestad contains an interaction between small sections of outlooks and panoramic views. Meandering streets flanked by buildings allowing the horizon to break through now and then.

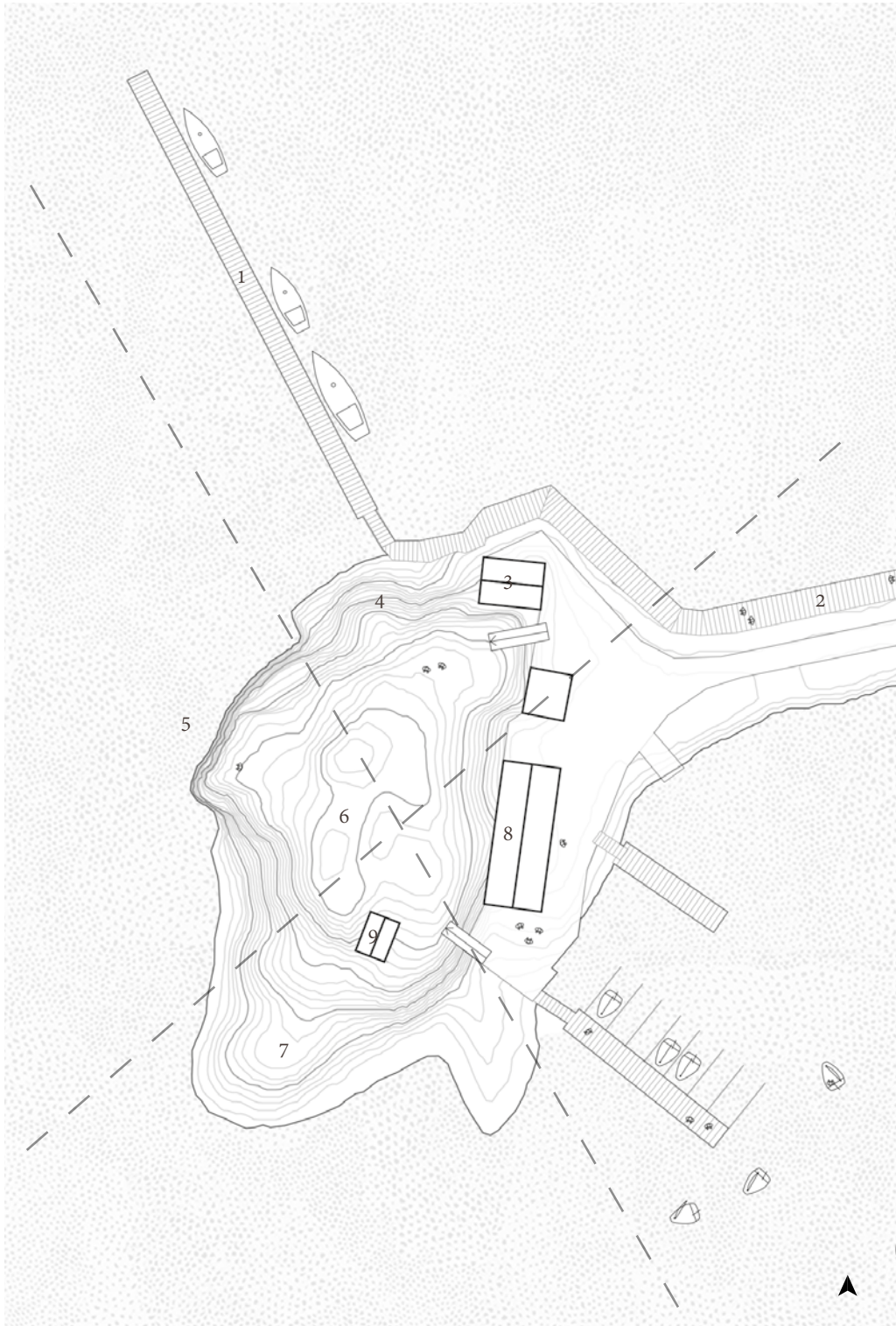


The building continues existing walking paths, following the expansion of the terrain. The locations communicate with its surrounding differently, making either the connection to the community or nature more important.



Vadskär

In the northern Bohuslän, Grebbestad is located about 8 km from the highway that extends from Gothenburg to Oslo. Public functions and services are shared between Tanumshede and Grebbestad, both located in Tanum municipality. Tanumshede holds the essential community services, as health care center, school, library, and municipality building, while Grebbestad, to a larger extent, is focused on tourism and fishery. In a town with an apparent relocation of inhabitants and a population older than the national average, Grebbestad Folkhögskola contributes both to young people as more service to stay open all year.



scale 1:800

- | | |
|---|-----------------------------------|
| 1. Guest harbour | 6. Viewpoint |
| 2. The bridge connects
to the pier promenade | 7. Great place for
morning dip |
| 3. Toilets / shower | 8. BJK boat club |
| 4. Uneven ground | 9. BJK sauna |
| 5. Steep cliff | |



View to North
 The community
 Stöberget
 The church
 Parking lots
 Fishery

View to East
 The promenade
 Guest harbour
 The beach
 Camping
 Commercial

View to south
 Boathouses
 Undulating landscape
 Sea
 Boats
 Horizon

View to west
 Granite and trees
 Opposite side
 Harbour entrance
 Boats
 Sunset



The seasons have an impact on Vadsjär. Both the weather and tourism change the island over the year. In summer, Vadsjär is a place for swimming, ice cream, and sunset. From April to October, the boat club contributes with visitors but the buildings are mostly empty in the winter, when neither the boat club nor the guest harbor has its activities running. Nevertheless, Vadsjär is not deserted in the winter, the island is still a nice stop during a walk and under the quieter conditions, the wildlife, with birds and an occasional seal, can get space.

So while nature still has its grip on the part of the island where the waves crash and the storms are at their hardest, the other side, facing the mainland, is clearly marked by man. The flat ground is laid out of stone and macadam and the buildings are simply designed in practical relatively modern materials. All buildings are painted red and more or less reminiscent of the classic boathouse, even though none of them have that function.

DISCOURSE

Discourse

This chapter covers the theoretical investigation of the work that provides a broader understanding of; the notion of place identity in relation to the topic; how architects relate to place and uses narrative as a tool exemplifying with two architectural references; public space in a rural context leading into the sauna proposal. Firstly, we will add on to the already started examination of narrative, by discussing the concept in relation to place.

A definition that is close to our understanding of the concept *narrative*, in the context of this thesis, is narrative as “a story that connects and explains a carefully selected set of supposedly true events, experiences, or the like, intended to support a particular viewpoint or thesis.” (Dictionary, 2021). Narratives are thus not rooted in reality, meaning that narratives connected to places, place narratives, can originate in the past or may as well derive from an idea of what a place may be in the future. Place narrative is closely related to the concept place identity, both ways of discussing how places are constructed in relation to humans. Place identity describes what makes a place unique and special compared to other places while a place narrative can affirm or deny an identity. It is also in theories of place identity that we will now begin to unfold the relationship between people and places.

Two theories of place

Place identity derives as a reaction to modernist ideals of generality and the idea of place as a location; first through the phenomenological idea of place identity, which was then developed and criticized from several angles (Creswell, 2004). We have chosen to engage mainly two (opposing) perspectives of place identity, represented by Christian Norberg-Schulz’s (1999) phenomenological theory of *genius loci* and Doreen Massey’s (1994) theory of place as a relational human construction. Both theories are comprehensive and complex, which is why we have limited our studies to the relationship between human identity and place identity.

Norberg-Schulz (1999) was a Norwegian architect and architectural theorist who

originated his thoughts in the philosophy of phenomenology, the individual experience of things. To describe specific and unique features of a place, he uses *genius loci*, the spirit of place with “environmental characters” to be found in features like materials, textures, colors, and forms. With changes in time and conditions like weather, the character of the place alters. Norberg-Schulz also introduces lifeworld and everyday life in the discussion of place identity. By living with a place, eventually, the human identity is affected and shaped by the place’s identity (Norberg-Schulz, 1999). Genius loci is a well established and used concept but is also criticized for simplifying place identity and striving for one true and authentic interpretation of place by mainly addressing the material features (Creswell, 2004). The Marxist and feminist geographer Doreen Massey (1994) argues for a relational place theory which departs from human relations and processes as constructors of place identity, contrary to Norberg-Schulz’s (1999) theory that the inherent qualities of a place shapes human identities. Massey (1994) further believes that a place thus never has a single identity, rather there are multiple identities existing parallel to each other. This also leads to an interpretation of place

identity as something changeable where our backgrounds and experiences, as groups and individuals, become part of the place.

The relational approach problematizes simplified stories about places and promotes a discussion of inclusion and exclusion that is necessary when trying to challenge prevailing norms and ideals. The inherent genius loci are at the same time highly present and accurate when talking about place identity, not least in a place like Grebbestad so clearly characterized by its physical conditions. This is to be seen not least when talking about a tourist perspective of Grebbestad.



Place identity

1. Growing up from the ground
2. Bumping back and forth

The tourist gaze

Tourism is not just a consequence of natural or preexisting features, the tourist place is created and shaped through the *tourist gaze*, a concept used by the sociologist John Urry and professor in tourism studies John Larsen (2011) to describe how tourism is part of constructing a place. Urry and Larsen use the metaphor of a sandcastle to explain this:

A particular physical environment does not in itself produce a tourist place. A pile of appropriately textured sand is nothing until it turns into a sandcastle. It has to be designed into buildings, sociabilities, family life, friendship, and memories. Places emerge as 'tourist places' when they inscribe in circles of anticipation, performance, and remembrance. (p. 101)

Thus, it is not only Grebbestad's identity of inherent qualities that is interesting for tourists as a group; the tourist's idea of Grebbestad is also part of forming the dominant narrative.

Urry and Larsen (2011) mean that the tourists seek away from everyday life into authentic experiences of other times or places and that tourist experiences must involve aspects



Fig. 3 Cold bath in Helsingborg

and elements out of the ordinary. There is also a request for authentic and genuine experiences of places. This is confirmed by the West Sweden Tourist Board in *Guide till bilden av Bohuslän* (2014), developed in collaboration with business, organizations, and municipalities. In the strategic document, the image of Bohuslän as a trademark is defined. It explains what, from tourism in general, is desirable: "The importance of the unique and local story continues to increase, as visitors chase authenticity, uniqueness and something to pass on to their friends"

(p.4). With authenticity and extraordinary as significant attractors for tourists, specific attributes, buildings, monuments, or parts of history will be necessary for places dependent on tourism. This also results in other features being less valuable for the tourist gaze. Everyday life could thus be exotified in certain areas and hidden away in others.

The document makes clear statements regarding what is attractive about Bohuslän from a tourist perspective. The physical environment is described:

In Bohuslän, you have a view in all directions. Here, the sun goes down into the sea, and everything is within close distance. Around every corner, new places emerge: charming small archipelago communities, picturesque crowds of red and white houses, marinas, boathouses, restaurants, and piers. (Turistrådet Västsverige, 2014, p.8).

This flattering portrait of Bohuslän is in many ways real, as it also exaggerates a rather static narrative of a place, reminding of a backdrop. Further on, the description of the trademark Bohuslän is not only about the physical environment but also portrayals of the people who live in Bohuslän.

People are always different, but they have one thing in common throughout Bohuslän; if you live every day with the challenges of nature and the sea, with islands, cliffs, sunsets - you gain perspective and become humble. It is close at hand to be - and to let others be themselves. (p. 9)

Nevertheless, we need hardly to point out that not all people in Bohuslän are humble. Probably the Western Sweden Tourist Board also agree on this but consciously or not, they make the people who live there part of the tourists backdrop.

The expectations of the physical environment are further described as: “Everything is expected to be beautiful and good design is taken for granted, while modern art is taking

“tourists seek away from everyday life into authentic experiences of other times or places”

up more and more space” (p.4). We find significant in this document, the importance of what image is communicated — to an extent that not only advice on what should be included in Bohuslän’s trademark is given, but also recommendations on what should be avoided. “There are also limits to the authentic / simple. For example, avoid muddy seafood or industrial details in pictures or too much plasticity” (p.13). The branding of Bohuslän is thus also about what is not Bohuslän. If these places want to keep tourism as a source of income, they need to relate to its requirements. The backdrop that the Tourist Board paints for tourists in its strategic document is the same place where the locals live. Is it then possible to refer to everyday life in Grebbestad rather as a backstage for the tourist backdrop?

The architectural gaze

Until now, we have discussed place in relation to human identity and the tourist gaze, arguing for the occurrence of a dominating narrative. Narrative composes as well a common architectural tool possible to consolidate stories and characteristics about a place. To examine the architect’s gaze on places we depart from Andrea Kahn’s text *Defining Urban Site* (2004). Kahn uses the notion of site as a description of the architect’s place of investigation. When defining a place, architects use *site representation*, a creative process of testing how a site could be constructed. This process is to be understood rather as how the architect thinks than what a place is. It can also be a story about places’ many different identities and realities, which contains both political, symbolic, aesthetic, and philosophical dimensions where the architect,

“Designers confront the challenge of defining urban sites through a creative process of representation”.
(Kahn, 2004, p.287)

through design, constructs knowledge of a place's truth (Kahn, 2004). Site representations are a way of contextualizing and arguing for a design as the architects explore a new site and create a narrative, linking the design to the site. Thus, the architect possesses the power to tell a story about a place - to choose which narrative or narratives desirable to share.

Transformation of place can not only be limited to the physical site, it also has a greater effect. A place can of course be delimited on a two-dimensional map, but in reality there are no clear boundaries. Places are unbound and linked to the surroundings. Every design intervention participates in a larger context than its material boundaries, considering space, scale, time and relational aspects. Kahn establishes three levels of knowledge for how an architectural proposal affects its surrounding; area of control, area of influence, and area of effect (Kahn, 2004). She includes both material and relational aspects of a design and makes clear that a design intervention always participates in a larger context of human relations, understanding and connection. This is also where we see the architect's contribution to confirm and deny narratives.



Architectural references



Fig. 4 Temporary Museum by Anne Holtrop

Studio Anne Holtrop

Holtrop describes his relationship to place and site as an act of tracing, tracing both material and landscape as drawing fragments such as shadows or paths (El Croquis). This approach examines spatial qualities in something that is not necessarily architecture, what he calls possible architecture (Porto Academy, 2018, 12 oct).

Holtrop advocates a gap of interpretation in his work, a dimension of something you do not yet know. In absolute or fixed reality an inkblot on paper is just an inkblot, but depending on our individual experiences we will all interpret it differently. The reality around us is not fixed but instead relies on what we project on it and how we engage with it, which also describes how Holtrop intends his work (Ray, n.d.).

Holtrop himself says that he does not have a political or social agenda within his work. He describes his work as more of an exploratory or

artistry kind, that is, a process of making and searching, and out of myriads of experiments, maybe one is worthwhile. And you never know when or how the interesting ideas unravel. To detect the specific one, Holtrop means that it appears to be sticking out as something unfamiliar, something unknown that you not really manage to position (Vennerstrøm, n.d)

This thesis is, on the other hand, engaged in both social and political questions. However, we state that a social or political agenda does not necessarily need to underlie the design. Following a search for something unfamiliar and different, Holtrop assists us with exciting ideas about taking advantage of space for interpretation in the design. In our context, characterized by a straightforward narrative, we can tune into the discussion of how to materialize the notion of friction (further explained in p. 44).

Raumlabor

Raumlabor is a Berlin-based collective of nine architects working in the intersection of architecture, city planning, art, and urban intervention. Abandoned places and urban areas in transition, described as difficult urban locations, are often recurring in their work. Close collaboration with the citizens and urban actors also seems essential for their work and the on-site and scale 1:1 approach. Raumlabor describes architecture “not as an object, but rather as history, a layer of the history of the place”. A tool with which they operate within the city “in the search for a city of possibilities” (Raumlabor, n.d.)

Raumlabor introduces their work as an intersection of several scales, and topics conducted in rather definitive matters are exciting. They challenge our preconceived ideas about architecture and fit both concrete and broader discussion within their work, as architecture becomes an excellent tool for building up places’ stories.



Fig. 5 Public sauna by Raumlabor

Public space

The political scientist Maarten Hajer (2001) describes a society consisting of different groups living parallel. Hence, public space works as transit zones where people simultaneously move without an actual interaction. Hajer's theories refer to an urban context with conditions different from Grebbestad. Neither the flow of people is as intense, nor is the population of defined groups as evident. Still, we can outline another division of groups present in Grebbestad containing permanent residents, part-time residents, and tourists.

Further on, Hajer's theory relates to how public space in Grebbestad is different to the groups using them. In this case, the groups instead move parallel to each other over a year rather than daily. Additionally, most of the physical environment corresponds to the requirements of summer residents and tourists; the opportunity to park centrally; live picturesquely; walk along the pier and buy ice cream, or sit in outdoor cafes in the evening sun. These are all qualities that do not exist during the winter months and become huge areas of asphalt and a pier promenade of

closed buildings reserved for next summer's visitors.

Based on the idea that public space functions as transit zones, Hajer (2001) reasons that functioning public space is not just about providing accessible spaces or neutral meeting places, such as urban parks and squares, that could work as a "clean" base for interactions without attracting or offending any individual or group. Instead, he argues that public space is an experience of a space where exchange between groups is possible, and actually occurs, which he presents as *public domain*. He suggests that public space fails to transfer into public domain when designed with "zero-friction" ideals:

Public domain experiences occur at the boundary between friction and freedom. [...] In the main, our public domain experiences are in fact related to entering the parochial domains of "others". In these instances there is, on the one hand, the dominance of another group; on the other, there is the possibility of personally deciding how far one goes along with the experience. (p. 116)

According to Hajer, the public domain benefits from being dominated by one group

as long as other groups are not excluded. In Grebbestad, tourists dominate public spaces during summer. The rest of the year, locals are the dominant group, but in spaces that are not dimensioned or designed for them.

Rurban perspective of public space

When discussing and defining public space in a rurban context as Grebbestad, we see different needs and functions than in the urban environments, so often used for stating examples in theory. The element of nature characterizes the area which questions the need for parks and green areas. Nature might not, in itself, be considered a public space, but with just a small spatial intervention, like a bench or a bathing ladder, it changes into a more pronounced shared facility. In a small town, other functions as the local grocery store can further function as a meeting place with a larger value than just consumption. Still, we see a shortage of public meeting places where more extended conversation may take place.

Historically, the church has possibly been a space with an important community function, during times when their values were more

widespread in society. The church was a place where all groups of society could meet but it is probably not seen as an inclusive space by everyone today. In a similar way, public baths and saunas have been central social functions in the Nordic countries (Nordström, 2019). During the second half of the 20th century, bathrooms became standard and more saunas were built in private homes. The bath went from a deeply collectivist activity to a more individualistic one. During the last years, public saunas and baths have again gained popularity (Linder & Wettainen, 2019). In Bohuslän, “badorter”, bathing resorts, have a long tradition that stretches back to the turn of the century of 1800. Most of the coastal communities have had facilities for the tourists to have a strengthening och refreshing bath in (Bohusläns museum, n.d.). The bathing resort has thus had the purpose of satisfying wealthy tourists, while the public baths and sauna have a more vernacular tradition.

Neither the church nor the sauna are neutral spaces. A distinct domination of a group or a culture could be sensed in the two. While the church belongs to the group of christians the holy place is still accessible for others to visit. The sauna, on the other hand, rather

requires respect for a cultural ritual with a spatial dimension that is experienced when entering. Some traditionalistic sauna bathers claims that sex, politics, business and religion should not be discussed in the sauna (Linder & Wettainen, 2019). Nakedness and sexuality is simultaneously difficult to separate from the sauna, which raises inevitable questions of power and equality. Still, some of the most distinctive features of the sauna is its contemplative unifying function, a space for conversation and consensus, with a strong physical presence in varying temperatures between the hot air and the cold water.

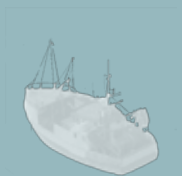
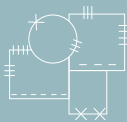
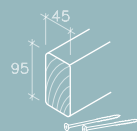
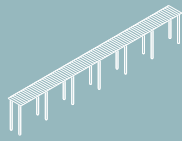
To summarize our theoretical framework. Grebbestad is characterized by a dominant narrative, not least maintained by the tourist's gaze. At the same time, we show how the place's narrative is also shaped through the architect's gaze, which gives us an opportunity to explore our own influence over the story of Grebbestad. Based on Hajer's theory and our own observations of this place, the dominance of tourism over the public spaces is obvious. By looking at historically important spaces for meetings in combination with our experience of other places in Bohuslän, the sauna is distinguished as an opportunity to provide

Grebbestad with a new kind of public space. By proposing a sauna at Vadskär, we can initially examine what alternatives there are to the dominant narrative and eventually suggest a space to the local population, where new conversations about Grebbestad can emerge.



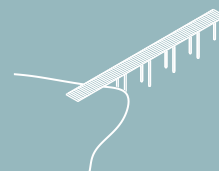
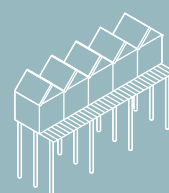
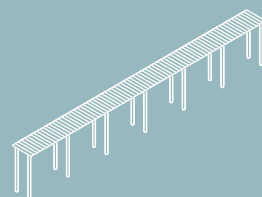


Fig. 6 Cold bath in Marstrand

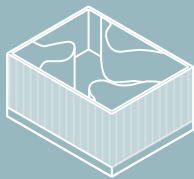


The Bath Narrative

The Bath springs from a well known narrative of Grebbestad as a seaside resort; a destination for bath, leisure and purification. It relates to other communities along the coast that share the tradition of cold bathing and is thereby filled with associations to history and the cold bath as an institution. The architecture of this type originates from a classicist style and follows a strict repetition and rhythm. The buildings are often located in the water, floating or piled up like a jetty, extending straight out against the horizon. The expectations seeing it from a distance are embodied in a straight and focused promenade.



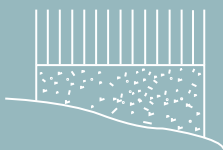
The Rock Narrative



Unaffected against the rough weather stands the rock. It's an intricate figure, silent like the landscape. It relates to the nature of the site, and confirms the idea of the magnificent and almost violent power of nature. A heavy concrete base is cast against the cliff, from which the sauna grows up. While the exterior is sealed, stepping into it, gives a clear indication to the rituals beginning. The inside refers to the soft, sun warm granite and undulating waves. Here you can sit and watch the horizon without being observed from the outside.

The Bath and the Rock are both related to dominating narratives of Grebbestad. The first is based on the idea of a place for recreation, healthiness and "tasteful" tourism. The Rock on the other hand, that builds on the untouched and wild nature, is not as obviously inviting the tourists, making it even more interesting and exclusive. They do confirm the idea of the beautiful and authentic place, embracing the unique but at the same time traditional features of Bohuslän.

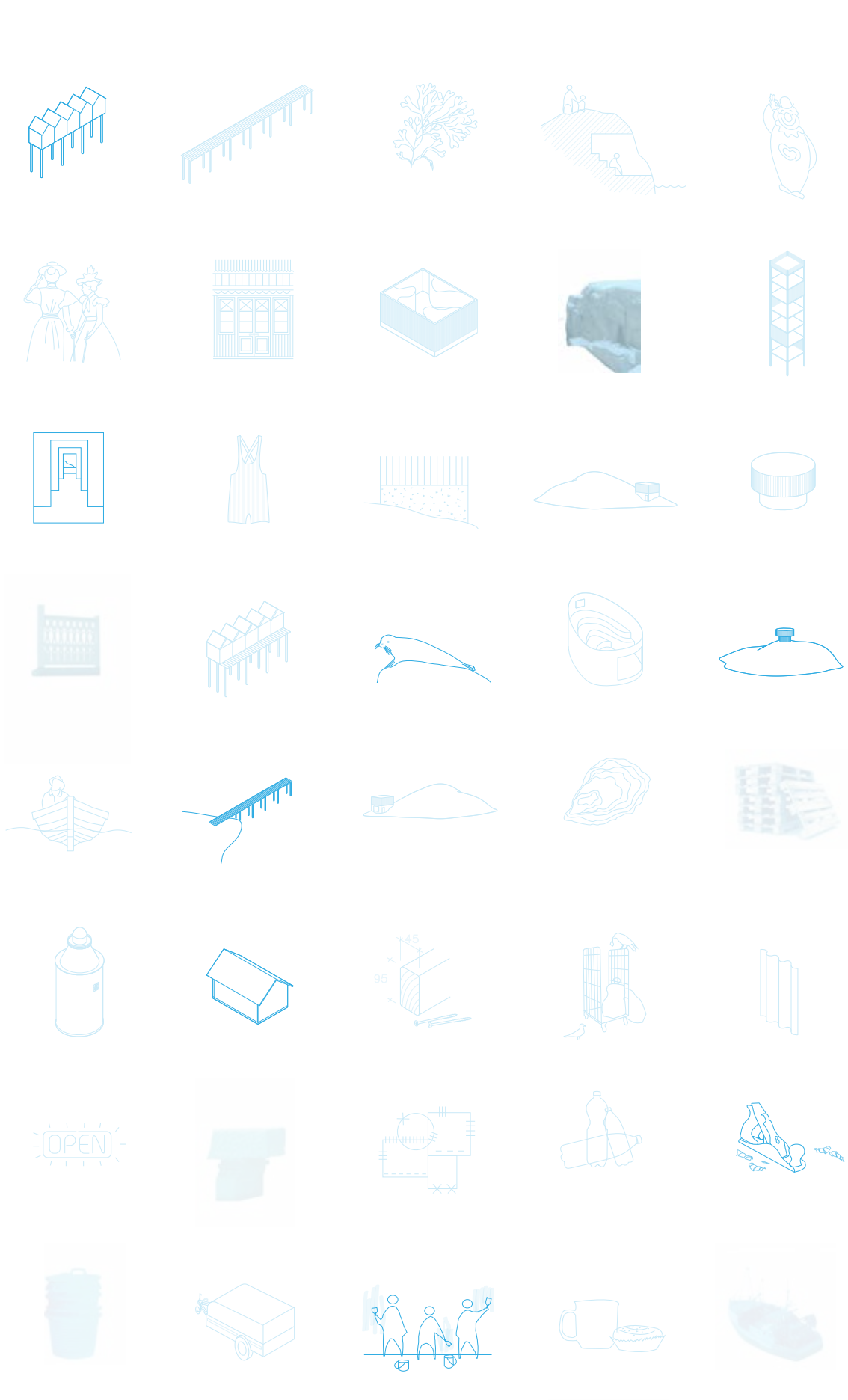
The Lantern positions itself in

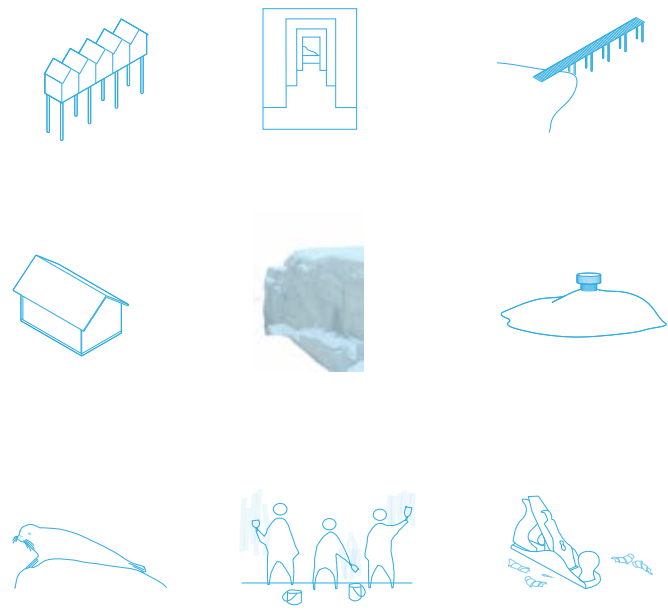


DESIGN PROPOSAL

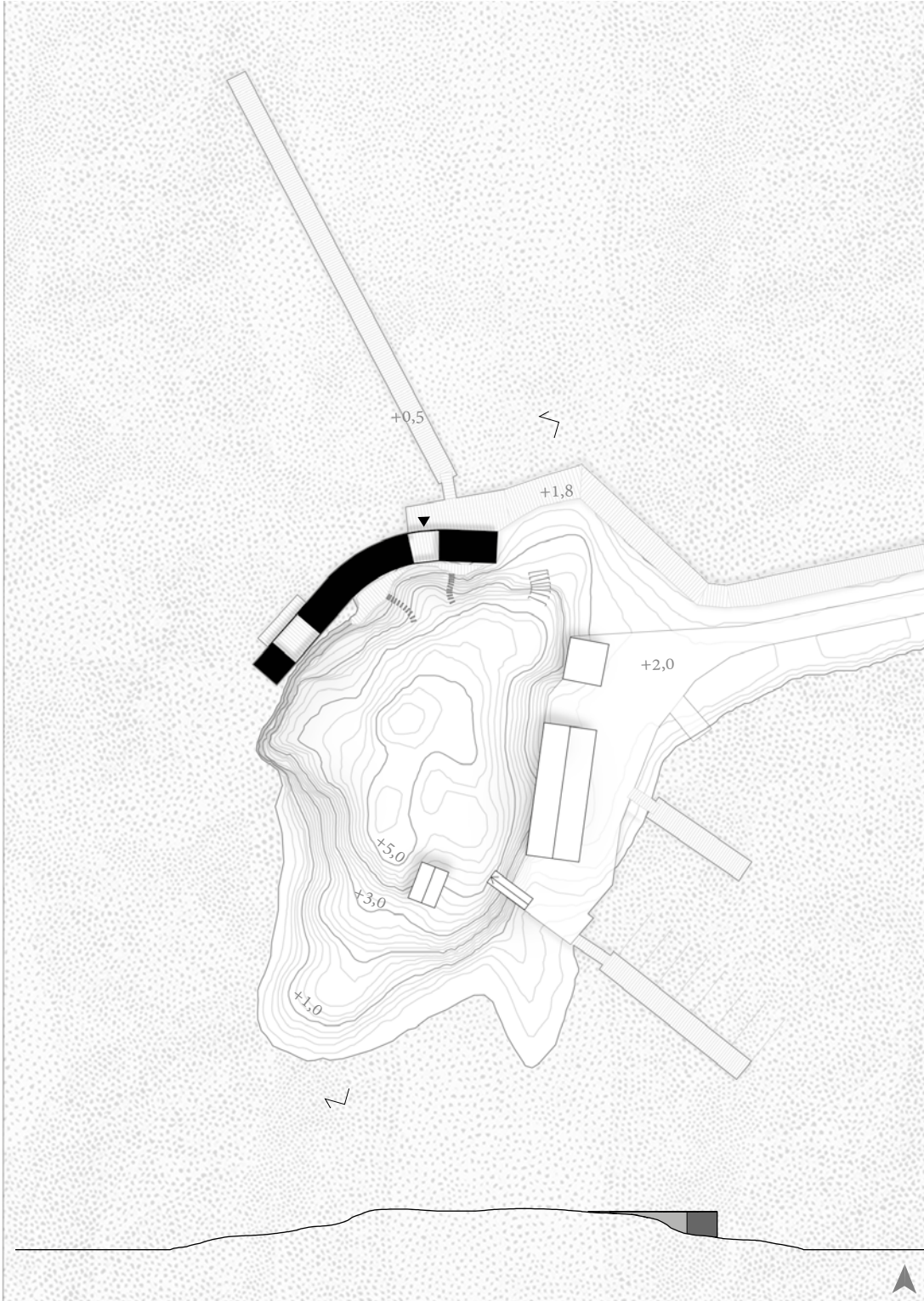








When continuing with the design proposal, we merge and separate the narratives again to bring with us a new combination of aspects. The *repetitive* form of the traditional bath, resulting in spatial *sequences* in the *extending* volume. The typologie of the *boat house's* relation to the landscape. *Visibility* without loosing *consideration of nature* and the existing animal life. *Engaging* different groups of the community and make use of *local knowledge*.



siteplan and section
scale 1:800

Approaching the building

The design proposal follows the idea of allowing the site to retain its character of both natural landscape and cultural events. The location leaves the sunny and nature-dominated southern tip unoccupied and instead appropriates for the island's more inaccessible northern part.

While the building's sense of character faces the community of Grebbestad and the promenade, entering Vadskär by foot, the sauna holds a much more unobtrusive sense. Accordingly, the encounter with the sauna when entering Vadskär is characterized by a sense of not dominating the islet. The building's gable helps to create an area in front which becomes Vadskär's entrance. From this point, the flow of visitors is separated leading either to the facilities or the bare landscape.

The proposal takes advantage of the shifting activities and intends to have clear dominating groups according to the seasons. A pragmatic attitude possible to derive from the local communities *Patchwork Narrative*. During the winter, the building's primary role is to be a place for the local population while in the summer months be used as a service building for the guest harbor's visitors. It is not primarily in the summer that meeting places for the locals are needed, instead, the needs of boat guests can be met and a synergy effect is created. The shifting use of the facilities creates a necessary economical incentive and a level of use that counteracts abandoned spaces in the winter time.



Approaching Vadskär by foot



A public sauna

The building stands with lightness in the landscape bridging the border between land and water like the common typology of the boathouse. The bent shape follows the curvature of the rock, creating an interaction between landscape and architecture.

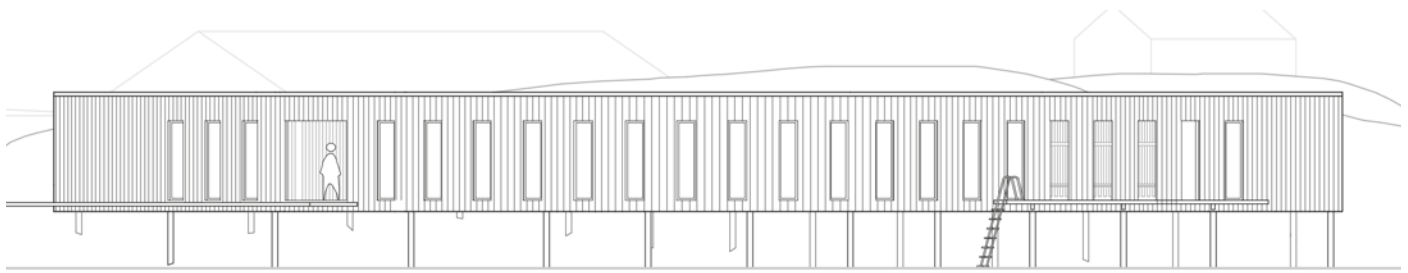
The building's bent shape follows the curvature of the rock, creating an interaction between landscape and architecture as the *Narrative of The Rock* and the common typology of the boathouse. Instead of using the boathouse as a building type we have tried to identify specific architectural values within it. This, for instance is, to approach a neat gable, and the elevated position above the water level. Often The boathouse has a two sided front as you either enter it from water by boat or from land that is also something we have tried to make use of.

A repetition characterized by the window placement miners of the bathhouse's appearance. The sauna is a bit hidden from the tourists gaze, but when standing at an empty parking lot next to ICA in november, it will light up out there in the dark deriving from the *Narrative of The Lantern* and its will to start a conversation between the community and the building.

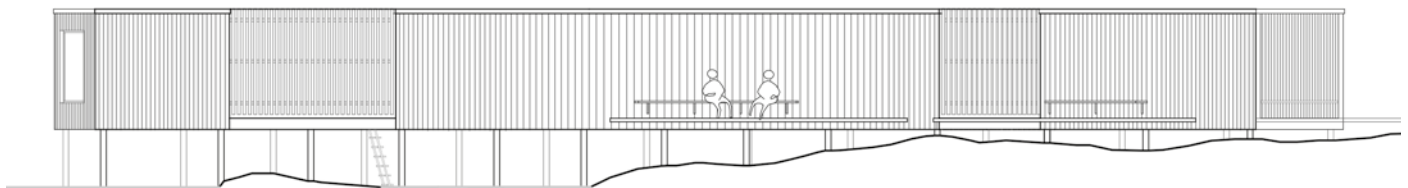


Fig. 7 Anne Holtrop Inkblot





north facade 1:200

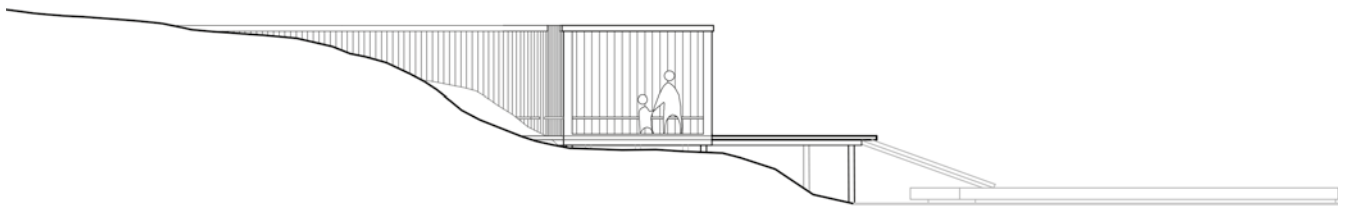


south facade 1:200

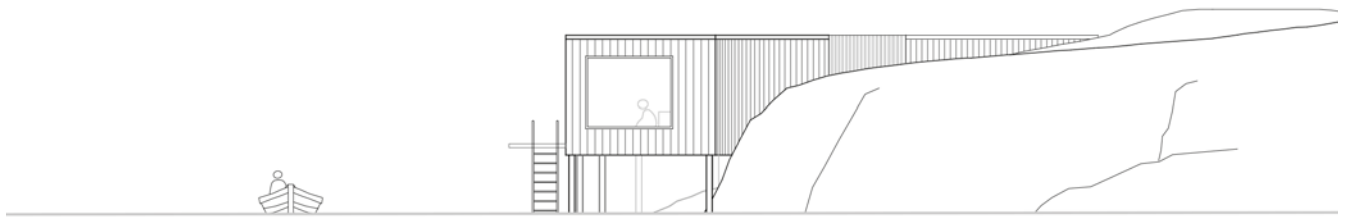
Exterior expression

The building consists of a timber stud construction, tin roof, and vertical wooden panel treated with black tar, supported by steel pillars. A light supportive and elevated construction, purpose to minimize the impact on marine life, which is an important part of the island. The elevated construction also withstand storm water and an increased water level.

The Northern facade faces the community of Grebbestad and lights up during dark hours. The Southern facade belongs to the islets nature-dominated area and offers a sunny and wind shielded sitting place. When approaching Vadskär from land you are met by the East facade, and in the very opposite end of the building the West facade faces the horizon in the sea to be seen from the sauna inside.

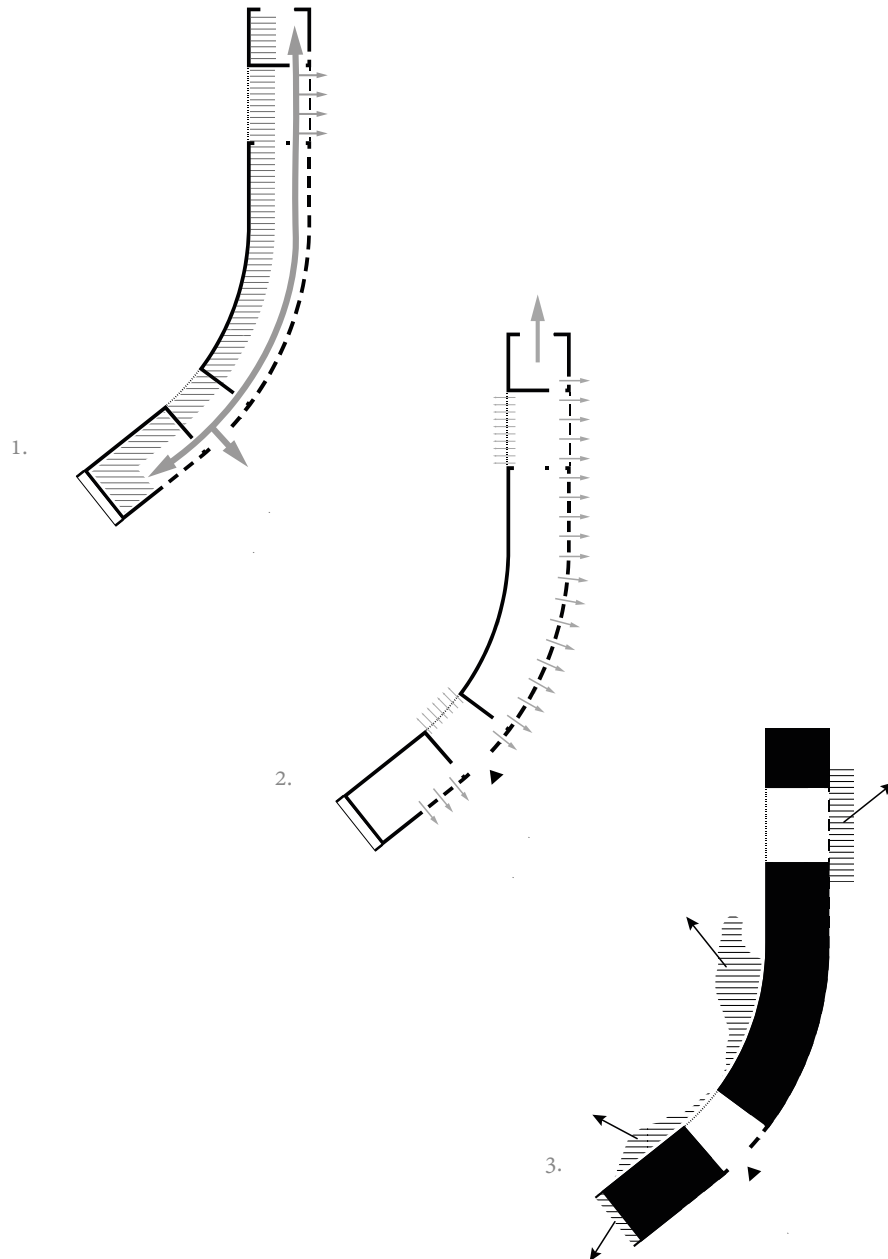


east facade 1:200

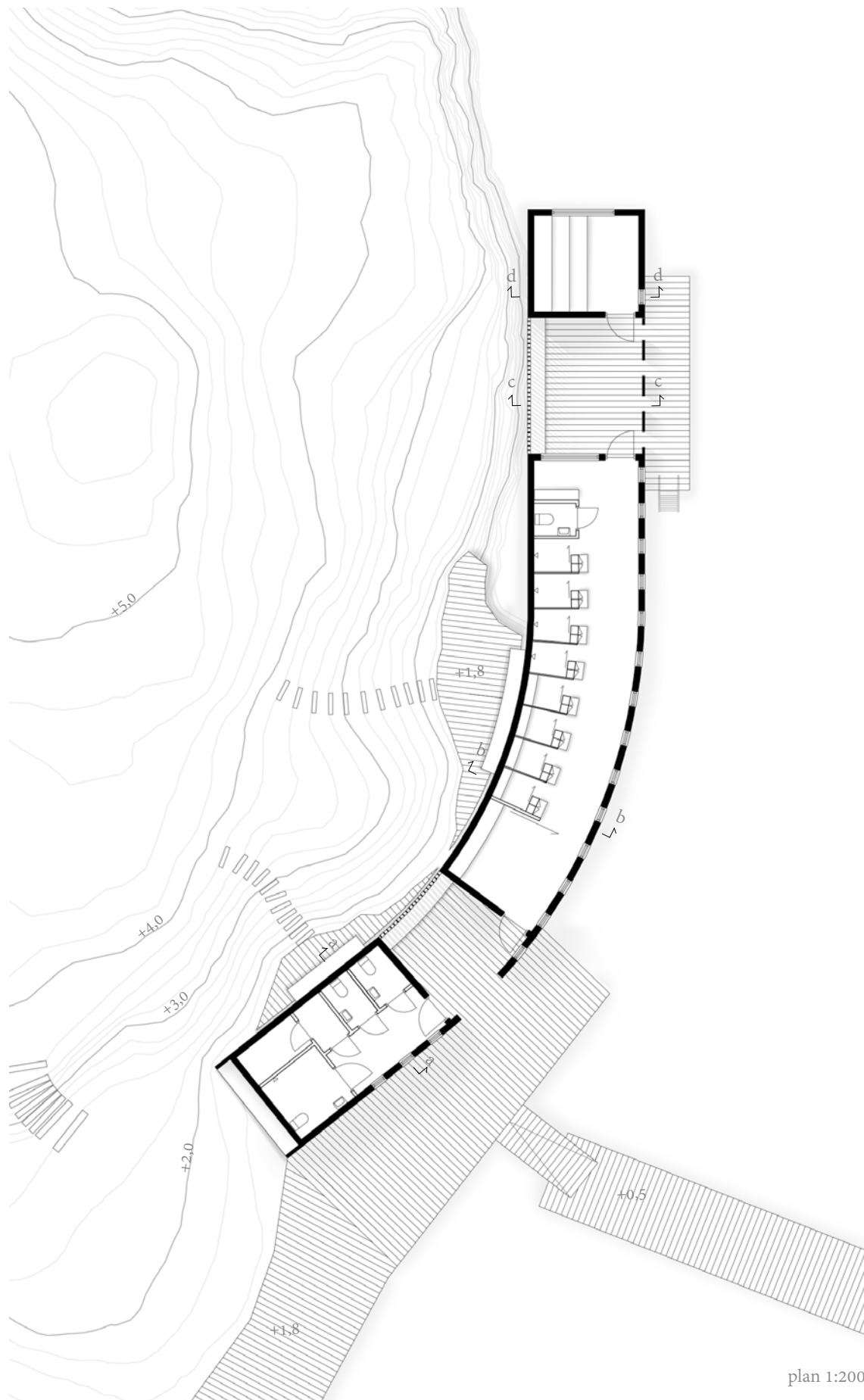


west facade 1:200

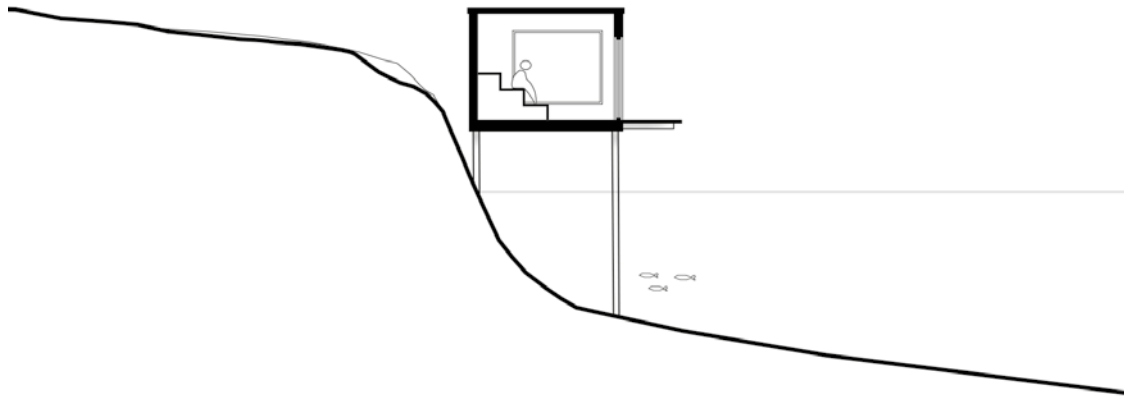




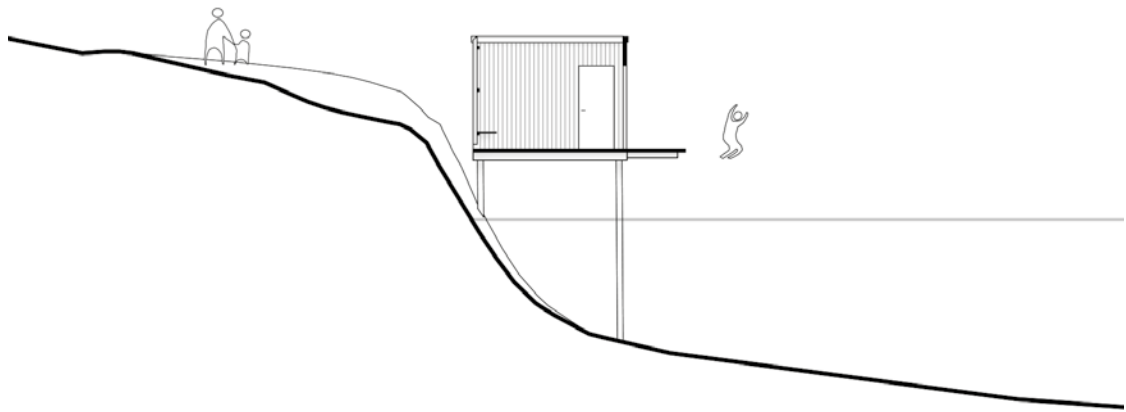
1. Communication and functions
2. Outlooks
3. Outdoor spaces



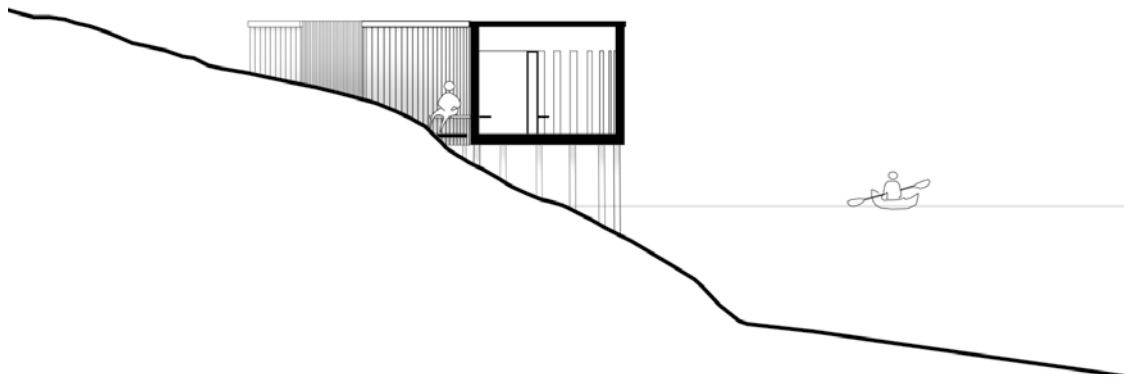
plan 1:200



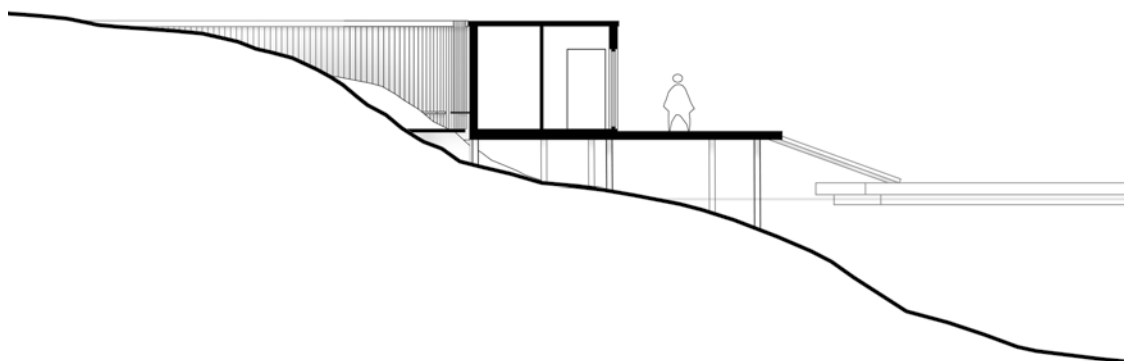
section d-d 1:200



section c-c 1:200



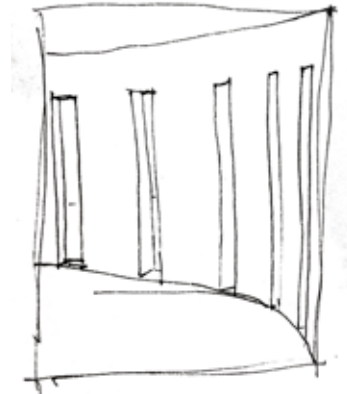
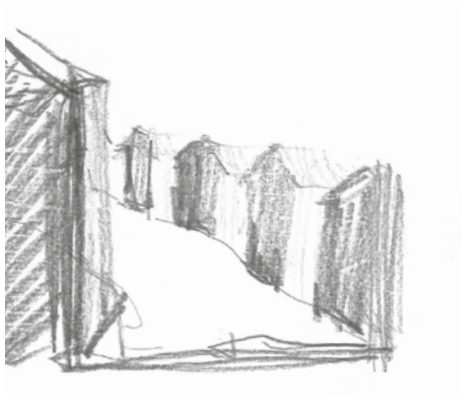
section b-b 1:200

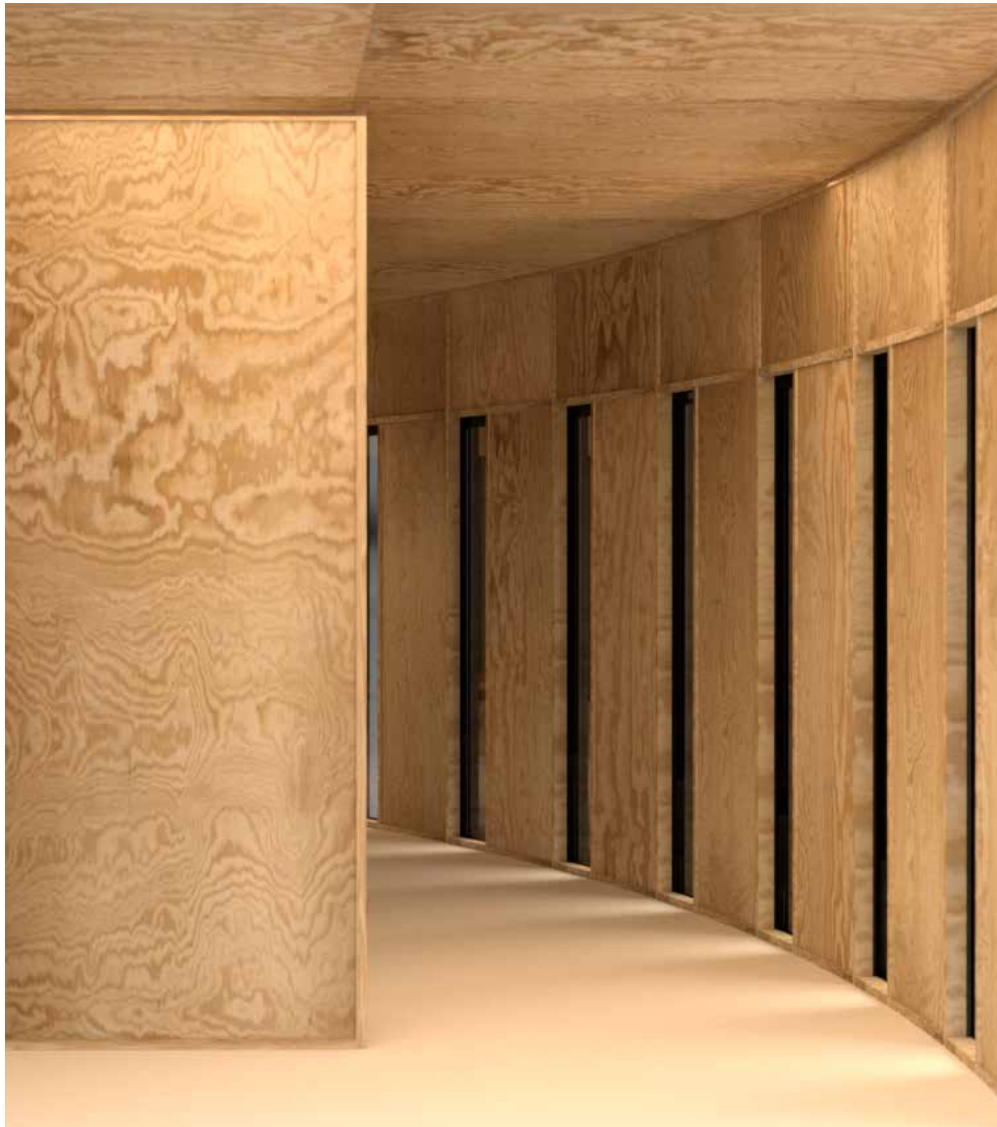


section a-a 1:200

Interior expression

The outlook setting refers to a walk through Grebbestad containing an interaction between small sections of outlooks and panoramic views as the visit is followed by a repetitive window placement ending up with a scenic view from the sauna. The building's rhythm is also possible to derive from *The Bath Narrative*.

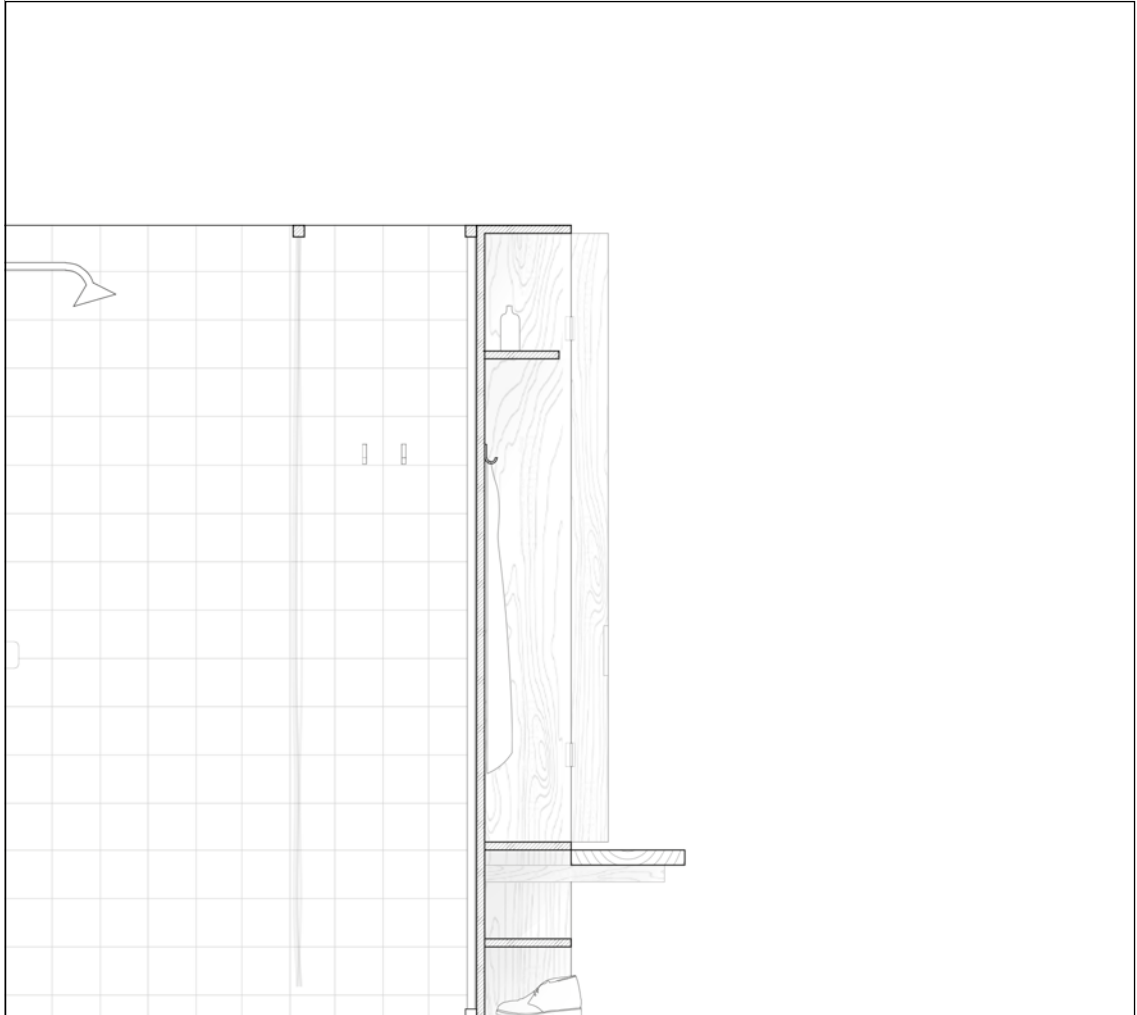






elevation 1:20

The overall interior is finished with a birch wooden board giving a warmth to the experience. The changing rooms and showers are concentrated to one unit whilst it consists of a number of smaller modules. The modules have a waterproof tile finish and make it possible to adjust the level of privacy in the dressing room. The doors can be closed completely or stand open, while benches and cabinets in the open space make it possible to let the conversation continue here as well. The use of the sauna may, into the winter, be divided into time slots, as well as it can be open to a wider public or booked for private use.



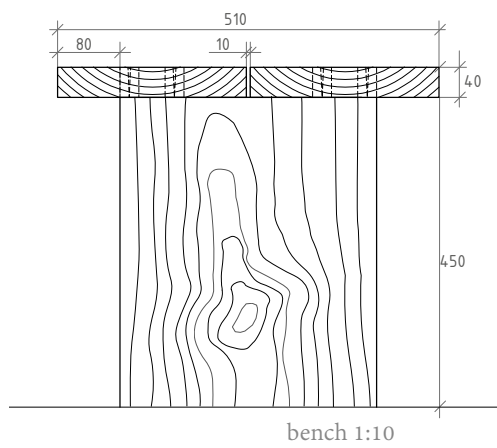
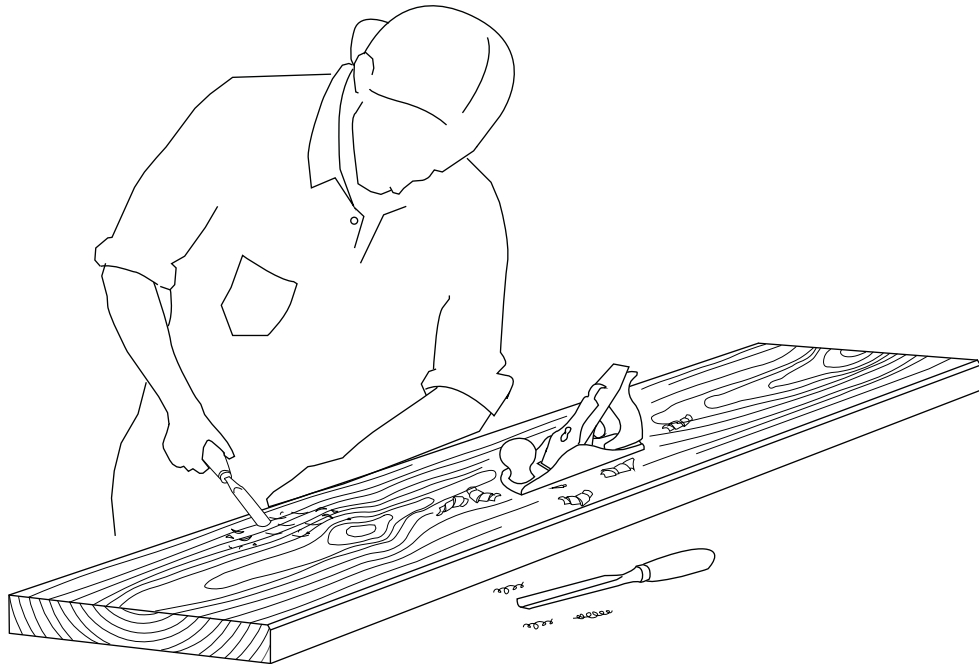
section 1:20



The bench

We see a possibility to make use of local knowledge in the project, by cooperating with students from the wood craft programme at the local folk high school. To be found in the patchwork narrative, local initiatives are a real asset in Grebbestad that is something to praise and engage but for that matter not exploit. In this way another group is engaged as well in the sauna, as the social context around it. This group differs from the rest of the community, both in age, background and place belonging. At the same time, the interior gets a touch and an impression from people who carry alternative stories about Grebbestad. The bench is a recurring element in the building both interior-wise and in the exterior, wall-mounted and freestanding. The benches become an element of solid wood where the type of wood can be adapted as needed; oak outdoors; birch indoors; aspen in the sauna. A bench in solid wood can be processed with hand tools, creating a tactile and individual finish.





DISCUSSION

Discussion

Place narrative and tourism

In this thesis, we have examined the tourists' gaze and the architect's gaze at places in general and at Grebbestad in particular. With the gaze fixed on the unique and the authentic in a place, one can say that there are similarities between the architect's and the tourist industry's attempt to distinguish and contextualize a place. The narrative is used in a similar way to construct a clear concept, sometimes simplified (and perhaps profitable), image of a place and relate it to its material environment. For understanding a place, we mean that there is more required than just looking at a dominant narrative, as for the idea of what the fishing villages in Bohuslän might be. You need to look beyond and for further narratives than the predominant, and understand that a place and its narrative is not static but constantly evolving and changing.

In Grebbestad, we notice how the traditional boathouse has become a reference for contemporary buildings. Symbolically, it aestheticizes the dominant narrative and gives it a material expression. Without further consideration of proportions, scale, and placement, a simplified local boathouse aesthetic maintains the tourist backdrop. As

we see it, this use of local characteristics for inspiration and references is not a coincidence or a local phenomenon in Grebbestad. When comparing with Gothenburg, for example, the narrative of a street in Berlin or New York could be used as an urban reference, as a city relates to a more extensive network or urban landscape. The urban environments, on the other hand, more often relate to the unique features of the place itself than other similar areas, which sometimes risk to end up like an idealized vision as a nostalgic reserve.

Based on the impact of the dominant narrative on small communities, related to the tourism in Grebbestad, a relevant question is whether this place in itself is extra fragile for these processes. In a society built around specific sources of income, such as the fishery in Grebbestad, decline or changes in these industries have major consequences. Tourism has become crucial for the survival of many coastal communities as it has become harder to make a living from fishing, but the dependency still makes these places susceptible to changes over time. The current pandemic is an example of how the conditions for tourism can drastically change. In addition to the risk of losing tourism as a source of income, there is also an excluding factor. How is it to live in

Grebbestad for those who do not want to be part of tourism? These aspects concern a long-term resilience of societal development, as the question of what environment created for the people living in it today.

Another consequence of the fact that tourism is an essential source of income for Grebbestad is that tourists become a dominant and financially strong group. The investments made in these places need to be in line with the narrative preferred by tourists, even if it may conflict with the needs of the local population. One way to finance investments is to combine new functions with a commercial activity aimed at tourists, such as a restaurant. When the tourist season is over, the spaces suddenly close or become oversized.

Public space in rural areas

When examining definitions and theories about public and shared spaces, an urban perspective usually has stated an example according to theories and research on the topic. Hajer's theory has been important for our discussion of public spaces in Grebbestad, although the concepts of friction and freedom are not entirely easy to apply in reality and

the rural environment requires a different approach. To remind us a bit, Hajer (2001) believes that neutral spaces are not desirable but that a public space can benefit from "belonging" to someone, he describes it as stepping into the "parochial domain of others" (p 116). This is also a possible way of imagining Grebbestad, a domain of the locals that tourists are welcome into. We would rather say that many places instead are domains of tourists, it is for them they are designed. Perhaps the maintenance of the backdrop that we have described, contributes to a dominating and one-sided usage of areas, while the backstage community has to deal with empty or overdimensioned areas.

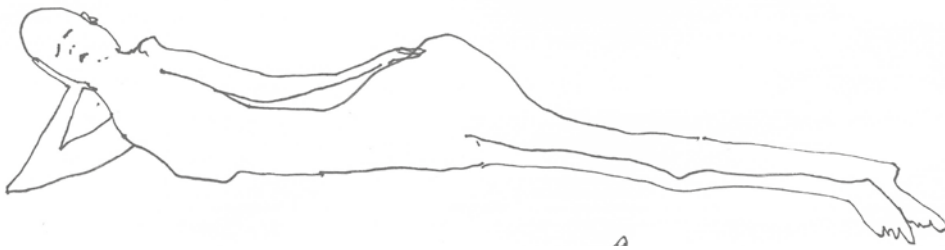
As we see it, the sauna contributes as a valuable function for social meetings in Grebbestad. It is not perfect or, in any way, the only one needed, but it states an example of how a public space can look and function in a rural environment like Grebbestad. We see the sauna as a space for more extended conversations than those conducted at ICA. Maybe a conversation where a narrative other than the dominant one can emerge and take place.

Based on this reasoning, we argue that summer-open restaurants, for instance, belong to a more urban culture where you can remain relatively anonymous but also are expected to buy something, such as a coffee latte. Tourism in itself could also be argued to be an urban phenomena where city dwellers escape a dense urban environment in favor of a rural life. The rural areas are then expected to stand by as a resource for the city dwellers.

In addition to the utilization and the economic synergy created in the proposal, the sauna states an example of an attractive function during more than just the summer months. The growing interest in saunas and cold baths is probably generating a new group of visitors who may most want to come here during the busiest time of the year to bath in a beautiful place.

Synergies

As financing is often a crucial issue for notifying the local population of earmarked investments, the sauna showcases how to achieve a synergy effect between the purchasing power of tourism and the, not infrequently, down-prioritized local population. Often, local initiatives are crucial for the development of the local community to be prioritized. It somehow becomes vital to find a balance between facilitating local initiatives and utilizing local resources and local know-how. Without, for that matter, hand the project over to local initiatives to take care of themselves.



Reflection

Narrative is used by the architect as a way of explaining and arguing for a proposal. We also create a narrative around a place when we work with it, to understand it, as what Kahn calls site representations. At the same time, it can be said that the narrative has a much larger role for a project during the negotiation process before the idea is realized. We (as architects) own the story of the building until it is built. When the architect's job is finished and the building is in place, people can start to interpret it their own way - influence and be influenced by people who use it.

Besides the thesis's investigated topic, an exchange of theory and practice in a design

process is examined in the project. The theory contributes to an understanding of the wider context of relevance that is necessary while the sketching process/the practical part is more of a tool that uncover new questions, problems, and possibilities in the act of making. It is when being materialized and tested, the complex theories make the most sense. It is also difficult to deviate from how important concepts such as genius loci can be in a creative process. The more we know, the more we know we do not know, in the same way critical theories can become inhibiting. The practical work requires space for manoeuvre and a sense of inspiration to fully reach its potential.

List of references

- Bohusläns museum. (n.d.). *Hur såg västkustens badorter ut*. Retrieved 2021-05-10, from <https://www.bohuslansmuseum.se/samlingar-och-historia/hur-sag-vastkustens-badorter-ut/>
- Creswell, T. (2004). *Place: A short introduction*. Blackwell Publishing.
- Dictionary (n.d.) Narrative. Retrieved 2021-05-10, from <https://www.dictionary.com/browse/narrative>
- Gerards, S., & De Bleeckere, S. (2014). *Narrative Thinking in Architectural Education*. Hasselt University.
- Hajer, M. (2001). In Search of New Public Domain. NAI.
- Hannington, B., & Martin, B. (2012). *Universal Methods of Design : 100 Ways to Explore Complex Problems, Develop Innovative Strategies, and Deliver Effective Design So*. Quarto Publishing Group USA.
- Innocenti, T. (2019, sept 28). När sommargästerna lämnar går Mollösund i ide. *Göteborgsposten*. Retrieved 2021-05-10, from <https://www.gp.se/livsstil/tv%C3%A5-d-agar/n%C3%A4r-sommarg%C3%A4sterna-l%C3%A4mnar-g%C3%A5rmoll%C3%B6sund-i-ide-1.18546587>
- Kahn, A. (2005). *Defining Urban Sites*. In Burns, C. & Kahn, A. (Ed.) *Site Matters* (11:281-296). Routledge.
- Larsson, L., & Robertsson, L. (2012). *Delårsboende i Norra Bohuslän: rapport från en intervjustudie*. Umeå University, Department of Geography and Economic History. Retrieved 2021-05-10, from <https://www.diva-portal.org/smash/get/diva2:783531/FULLTEXT01.pdf>
- Massey, D. (1994). *Space, Place and Gender*. Polity Press.
- Nationalencyklopedin (2021). *Narrativ*. Retrieved 2021-05-10, from <https://www.ne.se/uppslagsverk/encyklopedi/l%C3%A5ng/narrativ>
- Norberg-Schulz, C. (1999). Fenomenet plats. In *Arkitekturteorier: Skriftserien Kairos Nr 5*. Raster förlag.
- Nordström, U. (2019). *Nordiska bad: i sjö, hav, bassäng och källa*. Natur & kultur.
- Tanums kommun. (2018). *Grebbestad*. Retrieved 2021-05-10, from <https://www.tanum.se/kommunpolitik/kommunfakta/kommunenshistoria/ortsinformation/grebbestad.4.7664b4813898b7df9845a4a.html>
- Tanums kommun. (2006). *Fördjupad översiktsplan för Grebbestad*. Retrieved 2021-05-10, from <https://www.tanum.se/boendemiljoinfrastruktur/kommunensplanarbete/oversiktsplan/fordjupa-deoversiktsplaner/grebbestad.4.7664b4813898b7df984439f.html>
- Tanums kommun. (2009). *Planskiss Grebbestadskilen*. Event No 2007.413-410 Ks.
- Tanums kommun. (2010). *Kulturhistorisk bebyggelseinventering i Tanums kommun - Del 4a Grebbestad etapp 1*. <https://www.tanum.se/>

Tillväxt Bohuslän. (2009). *STRATEGISK PLAN för utveckling av Besöksnäringen i Norra Bohuslän*. Version 2009:2. Retrieved 2021-05-10, from https://www.tillvaxtbohuslan.se/wp-content/uploads/2014/02/Strategiplan_version2.pdf

Turistrådet Västsverige. (2014). *Guide till bilden av Bohuslän (A strategy document West Sweden Tourist Board)*. Retrieved 2021-05-10, from <https://www.tanum.se/download/18.6eaaddcd1576d4f0cc5ea1b3/1476108956439/Varum%C3%A4rkesplattform%20Bohusl%C3%A4n.pdf>

Urry, J., & Larsen, J. (2011). *The Tourist Gaze 3.0*. SAGE Publication.

Porto Academy. (2018, 12 oct). *Porto Academy 2017 Official Presentation :: Anne Holtrop Lecture* [Video]. YouTube. Retrieved 2021-05-10, from https://www.youtube.com/watch?v=xPMPmM_kKTU

Raumlabor (n.d.) *Raumlabor Berlin*. Retrieved 2021-05-10, from <https://raumlabor.net/>

Ray, D. (n.d.) *Possible Architecture: Anne Holtrop. Kinfolk*. Retrieved 2021-05-10, from <https://www.kinfolk.com/possible-architecture-anne-holtrop/>

Vennerstrøm, C. (n.d.) *Interview w/ Anne Holtrop*. Retrieved 2021-05-10, from https://architecture.mit.edu/sites/architecture.mit.edu/files/attachments/lecture/Edit04022014Interview-w.-Anne-Holtrop_Anne.pdf

Images

Fig. 1. Grebbestad. [Photography]. (2019). Bohusläns museum <https://digitaltmuseum.se/011014350953/grebbestad>

Fig. 2. Grebbestad. Kallbadhuset [Photography]. (2019). Bohusläns museum <https://digitaltmuseum.se/011014491918/grebbestad-kallbadhuset>

Fig. 3. Helsingborgs Kallbadhus [Photography]. (2021). <https://helsingborg.se/uppleva-och-gora/kallbadhus/>

Fig. 4. Holtrop House [Photography]. (2018). <https://www.architectural-review.com/today/temporary-museum-lake-by-anne-holtrop-heemskerk-the-netherlands>

Fig. 5. Allmänna badet [Photography]. (n.d.). <https://raumlabor.net/bathing-culture/>

Fig. 6. Kallbadhuset, Marstrand [Photography]. (2014). Bohusläns museum <https://digitaltmuseum.se/011014340116/kallbadhuset-marstrand>

Fig. 7. Ink blot [Photography]. (n.d.). <https://www.maniera.be/creators/2/studio-anne-holtrop>

All other images are our own private.

